

▶ Motorized Stages ▶ Cross Roller Stages

X Stages 90 x 90, 125 x 125, 150 x 180, 200 x 250

V-CR method **0.75 A/phase** 0.75 A/phase motor

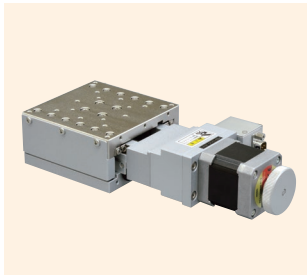

↑ TALS-904-H1PC

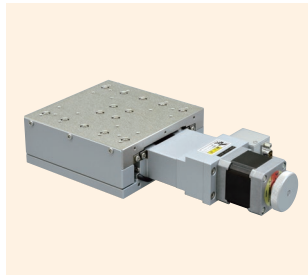

↑ TALS-106-H1PC



↑ TALS-150-H1P

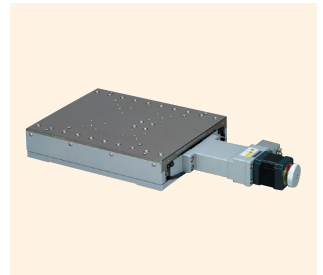

↑ TALS-215-H1P

Features

- A motorized stage that adopts a V-groove and cross roller guide for high precision.
- The travel guide and ball screw are coated with clean room grease.
- Can be used for applications for automatic positioning of various sensors and workpieces.
- Pre-home sensor and limit sensor positions can be adjusted.

Model number	TALS-904-H1PC	TALS-106-H1PC	TALS-150-H1P	TALS-215-H1P
Model name	X Stage			
Travel direction	X-axis single direction			
Travel amount	±20 mm	±30 mm	±50 mm	±75 mm
Stage surface	90 mm x 90 mm	125 mm x 125 mm	150 mm x 180 mm	200 mm x 250 mm
Motor used	PK545NBW equivalent (5-wire type pentagonal wiring, 0.75/phase)			
Resolution	0.002 mm			
Feed screw specification	Ball screw			
Feed screw lead	1 mm			
Travel guide	V-groove and cross rollers			
Travel accuracy	Straightness (horizontal/vertical): 0.003 mm		Straightness (horizontal/vertical): 0.004 mm	
	Yawing 15 s, pitching 20 s		Yawing 20 s, pitching 30 s	
Positioning accuracy	0.005 mm	0.006 mm	0.010 mm	0.015 mm
Repeatability	±0.0006 mm	±0.0005 mm	±0.0007 mm	±0.0008 mm
Lost motion	0.001 mm			
Moment rigidity	Yaw rigidity 0.3sec/N-cm, pitch rigidity 0.3sec/N-cm, roll rigidity 0.1sec/N-cm	Yaw rigidity 0.1sec/N-cm, pitch rigidity 0.1sec/N-cm, roll rigidity 0.05sec/N-cm	Yaw rigidity 0.02sec/N-cm, pitch rigidity 0.02sec/N-cm, roll rigidity 0.01sec/N-cm	
Load capacity	196 N (20 kgf)	392 N (40 kgf)	490 N (50 kgf)	
Mass	2.8 kg	4.9 kg	8 kg	14.5 kg
Maximum speed (at 8,000 pps)	16 mm/s			
Main materials/surface treatment	Steel: Electroless nickel plating (table), coating (base)			
Home position sensor	Normally open contact (make contact, A contact) operation, photo sensor			
Pre-home sensor	Normally closed contact point (break contact, B contact) operation, photo sensor			
Limit sensor	Normally closed contact point (break contact, B contact) operation, photo sensor			
Applicable cables	TACB-STD-D3, TARC-STD-D3			

◆ Sensor operating logic and timing chart

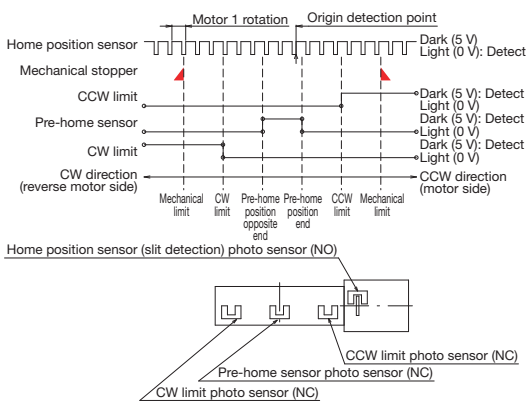

◆ Connection method: Connection cable and driver

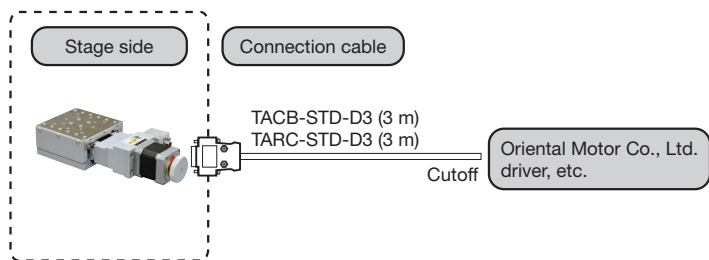



Cross Roller Stages ◀ Motorized Stages ◀

Product Appearance

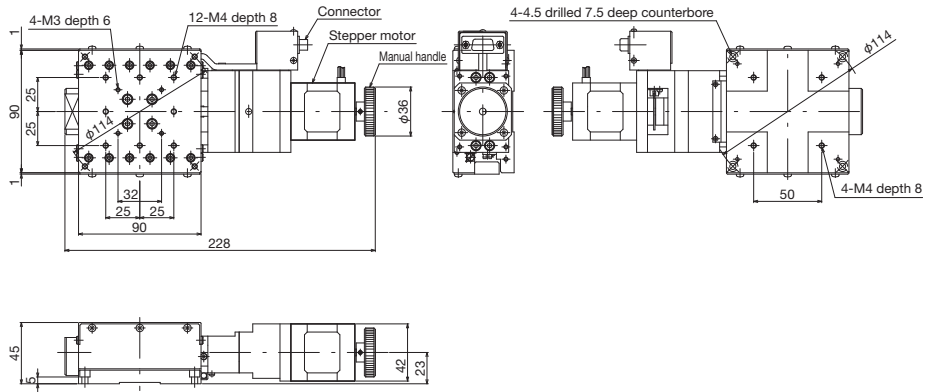

↑ TALS-904-H1PC

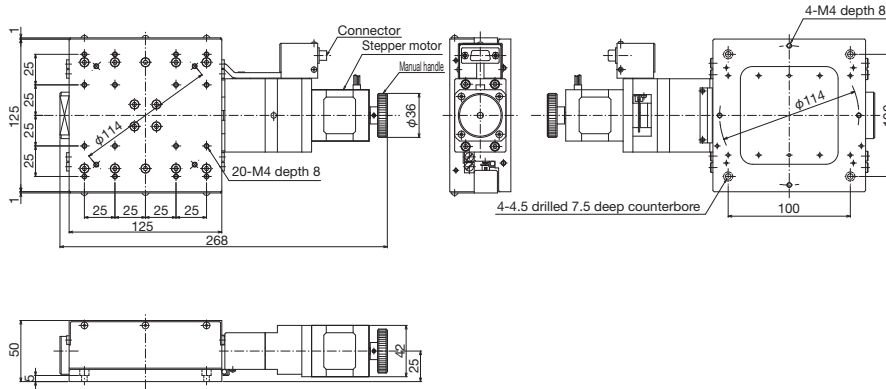

↑ TALS-106-H1PC

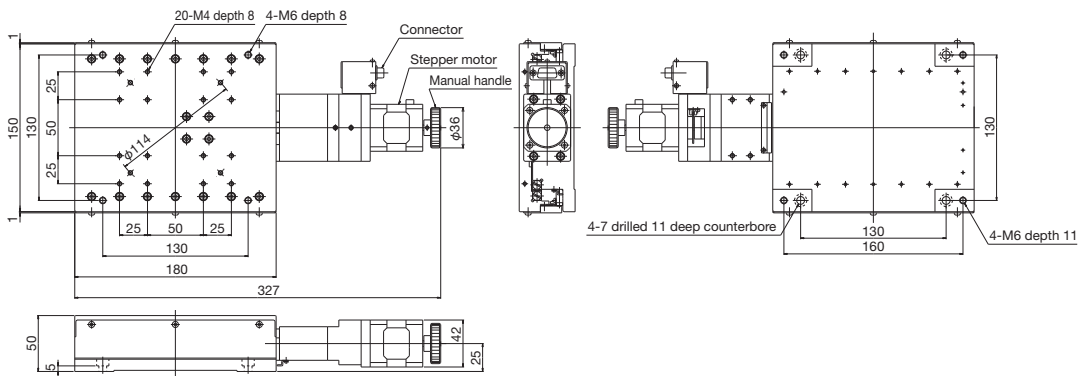

↑ TALS-510-H1P

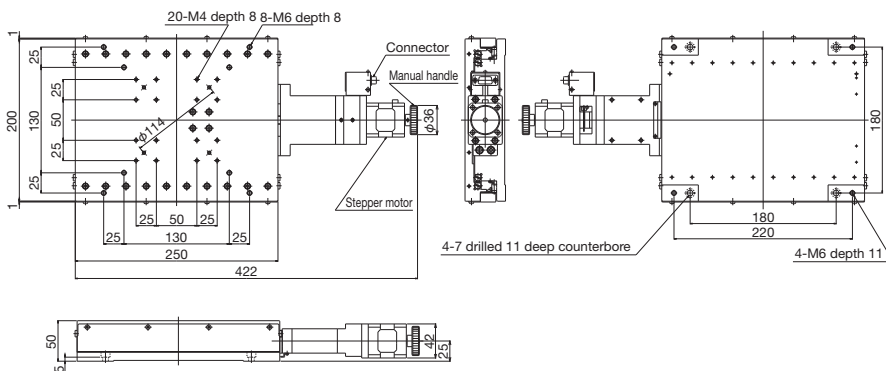

↑ TALS-215-H1P

Motorized Stages	Automated Products for Microscopes	Manual Stages	High-Grade Stages	30 mm x 30 mm (or 30 mm) Compact Stages	Cross Roller Stages	Ball Bushing Stages	High-Precision/High-Rigidity Stages	Z-Lift Stages	Tilt Stages	Connection Cases	Actuators
------------------	------------------------------------	---------------	-------------------	---	---------------------	---------------------	-------------------------------------	---------------	-------------	------------------	-----------